

Inverter + AVR

Home Inverter (EC+CC series)

User's Manual

Sine Wave Output

Models: 800 / 1200 / 1600 / 2400 / 3200 / 4000

Wall-mount & Tower type

IMPORTANT SAFETY INSTRUCTIONS

- When replacing the batteries, use the same number and the same type of batteries.
- Do not dispose of batteries in a fire; the battery may explode.
- Do not open or mutilate the battery or batteries, released electrolyte is harmful to the skin and eyes.
- A battery can present a risk of electric shock and high short circuit current. The following precaution should be observed when working on batteries.
 - * Remove watches, rings or other metal objects.
 - * Use tools with insulated handles.
- To prevent an overbalance of this unit, with the installation the additional stabilizer are to mount at the bottom side.
- This unit should be installed by service personnel.
- The equipment can be operated by any individuals with no previous experience.
- “The socket-outlet shall be installed near the equipment and easily accessible.”
- “With the installation of this equipment it should be prevented, that the sum of the leakage current of the inverter at the connected consumer does not exceed 3.5mA.”
- **Attention:** hazardous through electric shock. Also, with disconnection of this unit from the main, hazardous voltage still may be accessible through supply of battery.
- The battery supply should be therefore disconnected in the plus and minus pole through or from the outer enclosure accessible battery fuses when maintenance or service work inside the inverter is considered.
- The lead acid battery may cause chemical hazard.
- The battery presents a risk of electric shock and energy hazard.
- Batteries will be disposed by the manufacturer or importer. Customers need to send them back with no charge for disposal.

CAUTION:

- The inverter connection instructions and operation described in the manual must be followed in the indicated order.
- The inverter must be connected to a near by wall outlet that is easily accessible. The inverter can be disconnected from the AC-power source by removing the power cord.
- Check that the indications on the rating plate correspond to your AC-power system and to the actual electrical consumption of all the equipment to be connected to the inverter.
- Never install the inverter near liquids or in an excessively damp environment.
- Never let a foreign body penetrate inside the inverter.
- Never block the ventilation grates of the inverter.
- Never expose the inverter to direct sunlight or source of heat.
- If the inverter must be stored prior to installation, storage must be in a dry place.
- The admissible storage temperature range is -15°C to $+55^{\circ}\text{C}$.
- All handling operations will require at least two people (unpacking, installation in rack systems).
- Once installed and connected to the AC power source for the first time, the battery will start to charge. Full charging to obtain the rated battery backup time requires at least 8 hours.
- Before and after the installation, in case of any doubt, do Not hesitate to contact our service department.

Special Symbols

The following are examples of symbols used on the unit to alert you the important information.

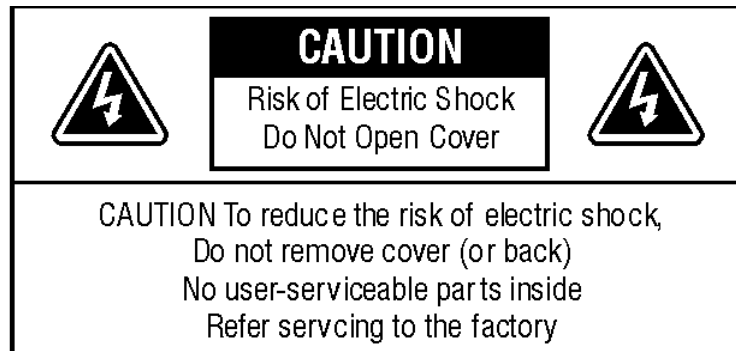

RISK OF ELECTRIC SHOCK -

Indicates that a risk of electric shock is present and the associated warning should be observed



CAUTION; REFER TO OPERATOR'S MANUAL -

Refer to your operator's manual for additional information, such as important operating and maintenance.



SAFETY EARTHING TERMINAL -

Indicates the primary safety ground.



RJ-45 RECEPTACLE -

For 230V units only, this receptacle provides network interface connections. Do not plug telephone or telecommunications equipment into this receptacle.

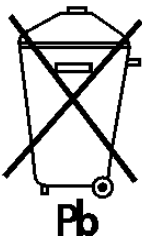

This symbol indicates that you should not discard the inverter or the inverter batteries in the trash. The inverter & the sealed, lead-acid batteries must be recycled.

TABLE of CONTENTS

1. Over view and Features	Page 5
2. Presentation	Page 6
2.1 LED display models	
2.2 LCD display models	
2.3 Rear Panels	Page 7
3. Installation	Page 8
4. Operation	Page 9
5. Indication and Control	Page 12
5.1 LED Display	
5.2 LCD Display	
5.3 Audible alarm	Page 14
5.4 Auto self-test Function	
5.5 Remote Control	Page 15
5.6 Reset the Inverter	
5.7 DIP Switch Setting	
6. Communication interface	Page 16
7. Trouble shooting	Page 17
8. Specifications	Page 18

1. OVER VIEW AND FEATURES

The series Inverter is advanced & friendly designed with pure sine-wave output to your equipment; besides a big charger up to 35A (depending on model), the inverter, unlike the traditional one, also provides a very short transference when blackouts happen; thus, you may apply it as an UPS, too. Further, it is also made with Wide Range AVR, output $\pm 10\%$ with input range as large as 140V ~ 310V in the rated 220V area; or 70V ~ 155V in the 110V area. With the wide AVR, you won't need to use the valuable battery energy when in a brownout. The series provides efficiency over 97% under normal power condition, and 86% under inverter mode. Two charge modes, quick and trickle charge, are applied in the big charger, and so as to maintain the batteries in the best condition.

With outstanding performance & reliability, the unique benefits of the inverter include the following:

- * Pure sine wave output.
- * Microprocessor based design with true Line-Interactive structure.
- * Adjustable charging voltage & voltage-transfer points.
- * Remaining Estimated Backup Time indication (EBT system on LCD version).
- * Smart battery management with intelligent double stages of charging control.
- * Real time auto-detection for battery condition.
- * Automatic restart of load after Inverter shutdown.
- * Smart AVR function (Two buck / boost modes).
- * Generator compatible.
- * "Green Power" design with auto on/off function & adjustable level.
- * Network manageable (SNMP optional).
- * Optional RS-232 interface for communication, compatible with all major O.S., including Windows, Linux, SCO UNIX, & DOS.
- * Protection for overload, short circuit, & over heat.

2. PRESENTATION

2.1 LED display models

There are many types of LED display for different models; however, they all use the same control method, the following is an example of it:

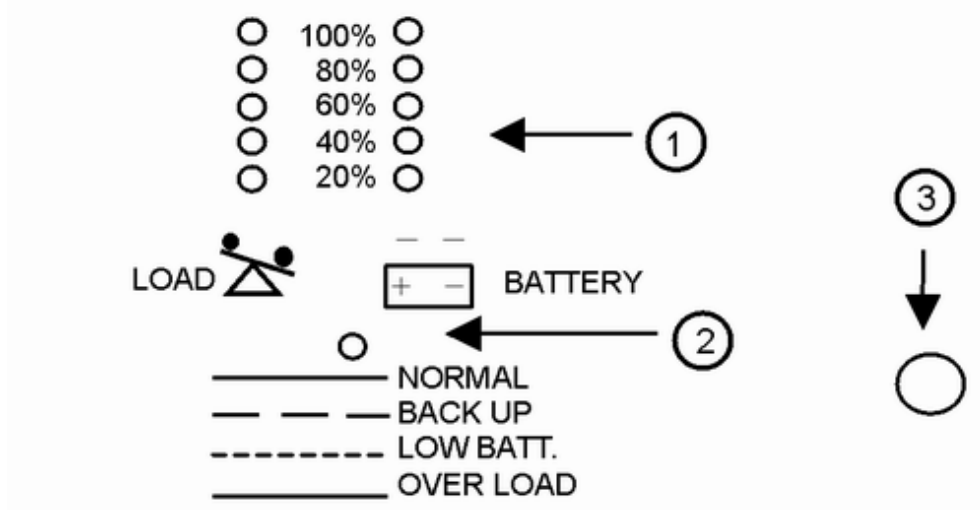

- ① LEDs of battery voltage level and load level.
- ② LED of operation status.
- ③ Control button.

2.2 LCD display models

The following is one example of LCD display; the location of control buttons could be different for some models; however, the functions of buttons are the same.

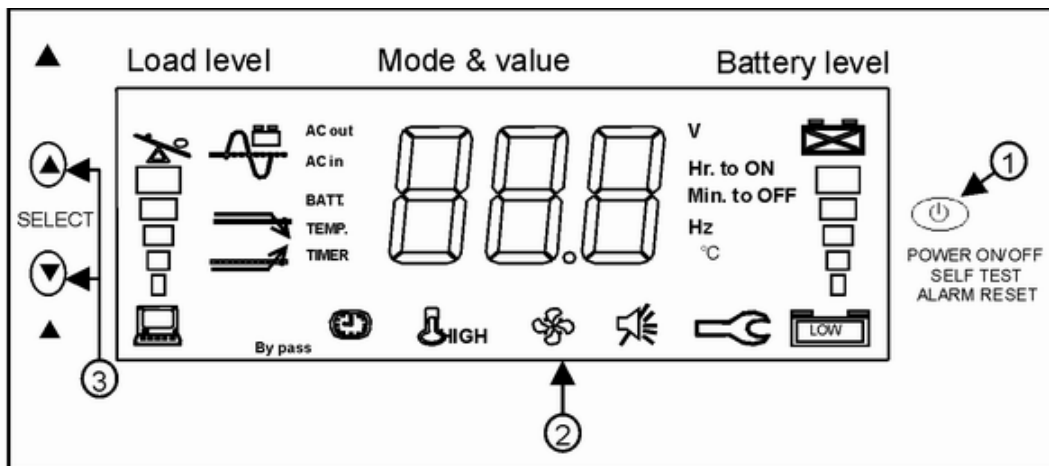

- ① Main control button.
- ② LCD screen.
- ③ Selection button for mode & value.

2.3 Rear Panels

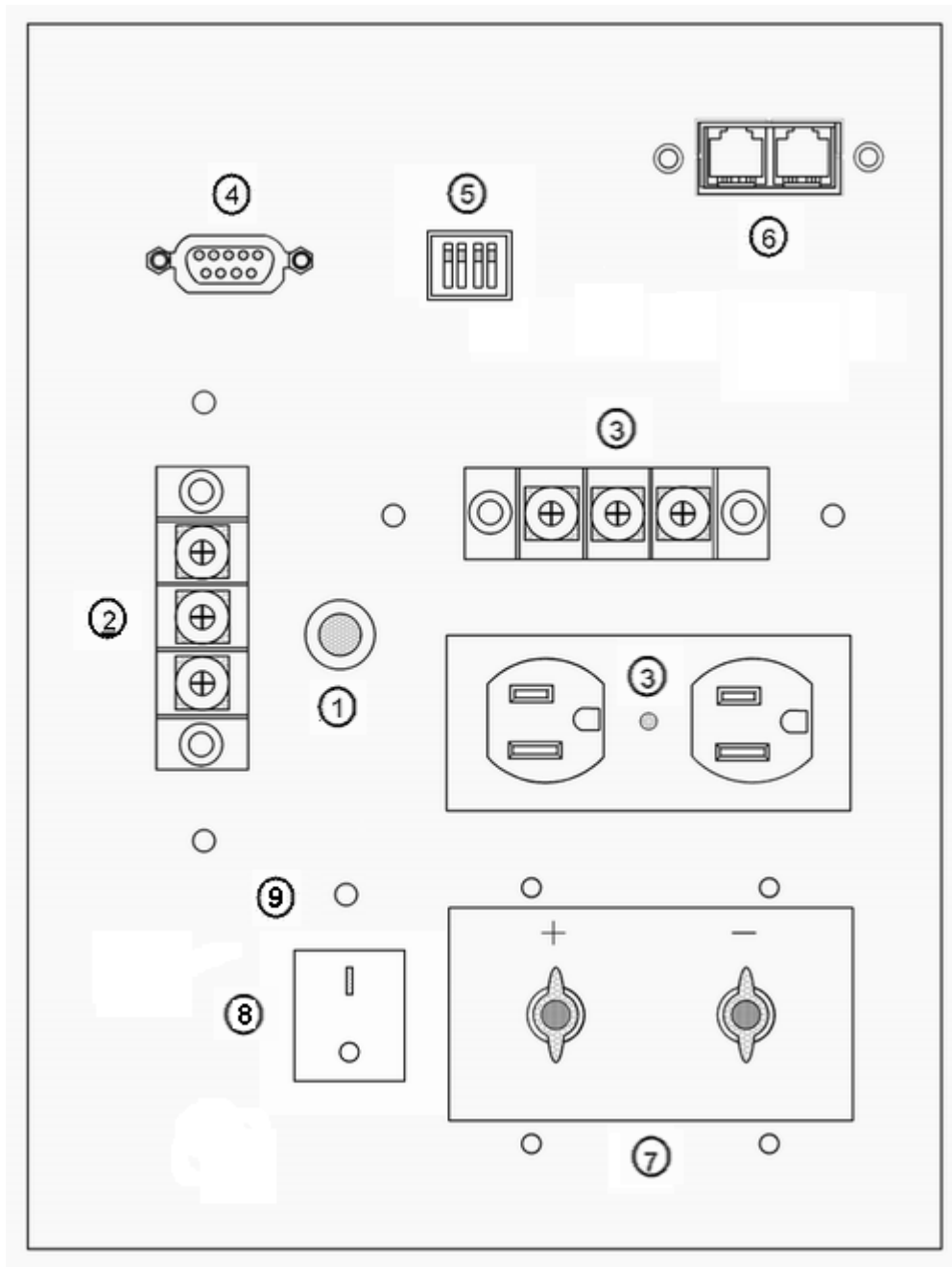

1. Circuit Breaker for Input.
2. Input Terminal.
3. Output Terminal and / or Outlet(s) (NEMA or IEC).
4. RS-232 Interface port (for application with optional Monitoring software)
5. DIP Switch.
6. RJ-45 Interface for Remote LCD display (Optional).
7. Battery connector.
8. Auto-bypass On/Off Switch (Turn on switch to enable Auto-bypass function).
9. Bypass LED Indicator

3. INSTALLATION

3.1 Inspecting the packing carton for damage that may have occurred while in transit. Immediately notify the carrier and place of purchase if any damage is found. Retain the package for future use.

3.2 Plugging the power cord to a 3-wire grounding receptacle. If an extension cord must be used between the Inverter and the nearest utility power source, use a 3-wire grounding type with rating, at least, for full load of input current as stated in item 8, Specifications.

3.3 Connecting the DC input power cord with the correct battery voltage and correct polarity, the inverter must be as close as possible to the battery to avoid the voltage drop on the power cord.

3.4 Connecting your equipment to the Inverter. To ensure your home appliances to be powered & protected during a utility failure, it is important to make sure that the maximum power needed by the equipment is not over the rated capacity of the Inverter. Red LED will light up (LED version), or the "Over load" symbol will show up (LCD version), and alarm will beep if the load is over the rated value. Meantime, if the overload is severe, the Inverter will shut down immediately for protecting itself.

3.5 Important Safety Instruction

SAVE THESE INSTRUCTION. This manual is important instructions that you should follow during installation and maintenance of the Inverter and batteries. Please read all instructions before operating the equipment and save this manual for future reference.

4. OPERATION

4.1 Once it's connected with normal city power, the inverter will charge the battery automatically, when inverter is off, the status LED (in LED version) blinks green every 2 seconds; or in LCD version, the battery symbol and battery level will blink every second during charging. If AC auto turn-on function is enabled, the inverter will turn on automatically when city power is normal. If auto turn-on is disabled, please push the button for about one second on the front panel; then the inverter will give power to the outlets after a short-time of beeping.

4.2 Pushing the button for 4 seconds, the inverter will turn off the power on the outlets. But, the inverter will keep charging if city power is normal. To stop the charging, please pull out the power cord to shut down the inverter completely.

4.3 **DC Start** : During a blackout, push the button one second for entering "OFF" mode (LCD showing "OFF" or LED blinking orange); then push again for one second, and the inverter will be turned on and enter into backup mode. To turn off the power from inverter; please push the button for 4 seconds; then the status LED (in LED version) will blink orange every 2 seconds; or LCD display will show "OFF" (in LCD version); then, wait for 10 seconds, and inverter will turn off the power automatically.

4.4 In "OFF" mode, inverter will turn off power completely in 10 seconds during a utility failure; while inverter will keep charging the batteries if the utility power is normal. When utility power is normal, please pull out the power cord if you want to turn off the inverter completely.

4.5 **Auto-Bypass** : When auto-bypass function is enabled, the inverter will transfer to by-pass mode any time when inverter is turned off. It prevents any power loss to the important equipment if over load or any abnormal situation triggers the shut-down function of inverter.

4.6 Under battery mode, when battery voltage is too low or too high, the inverter will emit alarm, if the under voltage or over voltage is too much, the inverter will turn off itself automatically.

4.7 When a blackout happens, the buzzer will emit two beeps every 8 seconds for alarm **during the first minute of blackout**. You can disable the alarm by a short push at the main control button, and to push it again will enable the alarm, the setting can be shown on LCD display.

Note: The main control button provides test function at normal mode, but will become with alarm-reset function at battery mode.

4.8 Battery charging mode: The inverter provides two charging modes for the battery, quick charging and trickle charging. The quick charging provides higher charging current when battery is empty and reduces the charging current when battery voltage increases. Trickle charging will begin automatically after battery is 90% fully charged.

4.9 Green mode setting (by the set-up software, UPS wizard; or through LCD display)

When “Green Power” function is enabled, the inverter will turn off the power within 60 seconds after blackout occurs with the power consumption lower than the pre-set level (adjustable from 1% to 14% of full load). The default value of green mode setting is zero (disabled). Please use the UPS wizard software to adjust this level.

4.10 There are two ways to change the setting of inverter. The 1st way is to use the UPS Wizard software, please contact your service people for detailed information. The 2nd way is to make it through the LCD display, by the following procedures:

4.10.1 To push the two selection buttons, \triangle and ∇ , at the same time for 3 seconds until the LCD display begins to blink.

4.10.2 To change the inverter O/P frequency at DC start

When the frequency value is blinking, push any selection button, \triangle or ∇ , for 1 second to change the frequency setting! The setting will keep changing every 2 seconds if you keep pushing the button. Push two selection buttons at the same time for next setting, or leave the LCD blinking without pushing any button for 30 seconds to end the setting.

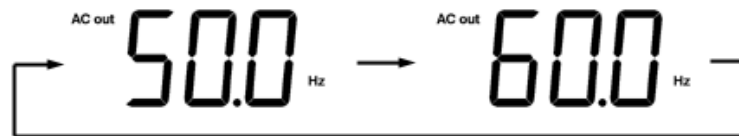

4.10.3 To change the inverter rated voltage

When the voltage value is blinking, push any selection button for 1 second to change the rated voltage. Keep pushing the button until the required voltage blinking. Then, push two selection buttons at the same time for next setting; or leave the LCD blinking for 30 seconds to end the setting.

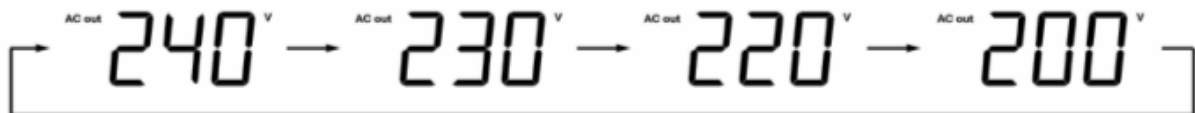

220V Series

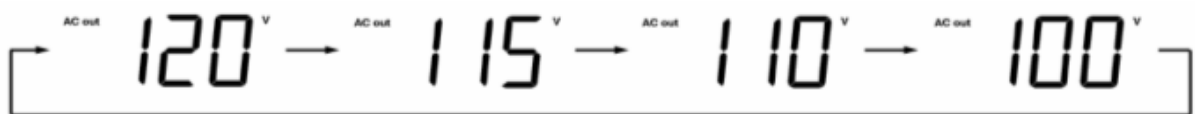

110V Series

4.10.4 To change the Auto-turn-on setting at the recovery of utility power

The method of changing the setting is similar to that of voltage setting. If you don't need Auto-turn-on function, please select "oFF". To select "On" is for immediate auto turning on at the recovery of utility power. While the "On.S" means auto turning on with safety mode. Sometimes, when battery is empty after blackout, the auto turn-on function will have very short backup time if blackout happened again following with a short time recovery. To select "On.S" will provide Auto-turn-on only when the battery is charged for, at least, 30% of its capacity.



4.10.5 To change the green mode level at battery mode

When the "Gn.0" is blinking, it means the green mode level is off. The inverter will not turn off the power automatically if there's no any load connected to inverter. When the "Gn.1" is blinking, it means that the green mode level is 1% of full load. The inverter will turn off power automatically if blackout happened when load level is less than 1% of full load.

Push the selection button "△" for 2 seconds at least, to increase the green mode level or push "▽" to decrease the level. Push two selection buttons at the same time to end the setting.

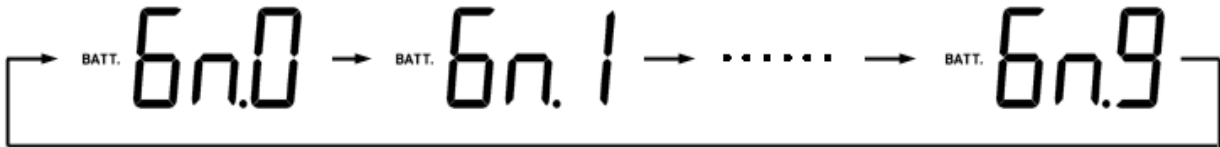

5. INDICATION AND CONTROL

5.1 LED Display

5.1.1 Battery level and load level LEDs

The battery level LEDs show the voltage level both in back-up mode and in normal mode. When the LED indicates 20% of the capacity in back-up mode, it means that the Inverter is going to shut down; for the length of backup time left, it will depend on the load. While when all five LEDs are lighted in normal mode, it means that the battery is fully charged.

The load level LEDs show the percentage of added load by the Inverter's rated capacity. When all five LEDs are lighted, the Inverter is over loaded.

5.1.2 Operation status LED

The status LED shows the Inverter status. It shows Green when the utility power is normal; and shows Orange in the event of a utility outage; while if the Inverter is under fault operation, it shows Red.

5.2 LCD Display

5.2.1 Main control button: Please refer to point 4 & 5 (4.1~4.7 & 5.3~5.4).

5.2.2 LCD screen

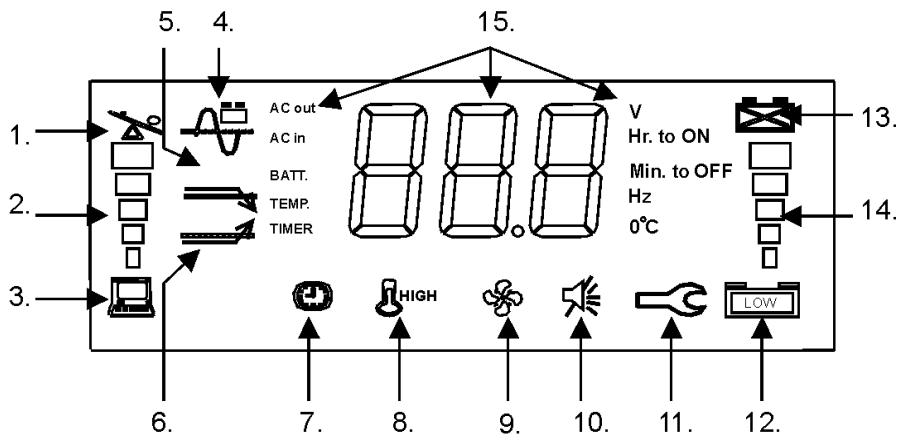

No.	Symbol	Indication	Description
1.		Over load	The loading exceeds the rating of Inverter.
2.		Load level	The higher the loading, the more bars will illuminate.
3.		Inverter is loaded	When "Green Mode" is enabled, this symbol will display if the loading is over 30W (default, but adjustable), and disappears when it's under 25W (default, but adjustable). Please refer to User's Manual 4.9. If "Green Mode" is disabled, the symbol will always display.
4.		Normal mode	1) The sine wave symbol will display steadily without battery symbol when Inverter is in the normal mode.
		Battery mode	2) The sine wave symbol and battery symbol will blink when the Inverter is in back-up (inverter) mode.
		Test mode	3) The sine wave symbol will display steadily with blinking battery symbol when the Inverter is in testing mode.
5.		Buck mode	The AVR (Auto Voltage Regulator) is reducing the output voltage of the Inverter (when the input voltage is too high), and the sine wave symbol, as mentioned in item 4, will also display steadily to indicate that the output is in the normal mode.
6.		Boost mode	The AVR is increasing the output voltage of the Inverter (when the input voltage is too low), and the sine wave symbol, as mentioned in item 4, will display to indicate it's in the normal mode
7.		Timer is enabled	This symbol will show up in the following situations: 1) A turn-on / turn-off schedule has been set using the monitoring software. Refer to User's Manual 5.5 and the "Readme" file or "Help" function of the monitoring software. 2) The Green Mode is enabled and the loading is under 25W (default, but adjustable). The Inverter will turn itself off automatically in 60 seconds. Refer to 4.9 of User's Manual.
8.		Thermal alarm	The temperature inside the Inverter is over 55°C. If the user does not reduce the load, the temperature will continue to rise and the Inverter will shut down automatically at 60°C.
9.		Fan is in "High speed"	The symbol will display whenever the cooling fan is running (or high speed), and will disappear when it is off (or low speed).
10.		Silence mode	The audible alarm has been silenced. To reset the alarm in Back-up mode, push the control button (not available during low battery level or abnormal condition).
11.		Inverter fault	The Inverter has failed and must be repaired. Contact a qualified service person.
12.		Battery normal	1) In normal operation, this symbol indicates a charged battery.
		Battery low	2) When the battery charge level is low, the word "LOW" will be added to the symbol.
13.		Battery replacement	The battery has failed and must be replaced. The battery is checked each time the Test Function is executed.
14.		Battery voltage level	1) The higher the battery voltage, the more bars will illuminate. 2) When the Inverter is charging the battery, the battery symbol and the level indicator will blink together.

15.	Mode	Value	Description
	AC out	V	AC output voltage.
	AC in	V	AC input voltage.
	AC out	Hz	AC output frequency.
	BATT.	V	DC battery voltage.
	TEMP.	°C	Inverter internal temperature.
	TIMER	Min. to off	The Inverter will turn off when the displayed value reaches zero. For example, if the timer shows 0.5 Min to off, the Inverter will shut down in 30 seconds.
	TIMER	Hr. to on	The Inverter will turn on when the displayed value reaches zero. For example, if the timer shows 48 Hr to on, the Inverter will turn on in 2 days.
	BATT.	Min. to off	The estimated remaining run time in Back-up mode. The accuracy of the value is influenced by the loading type, ambient temperature and battery condition (old or new).
Selection Button for mode & value			
All the operation data will be displayed on LCD screen. By selecting the required mode (upward or downward), the related value will be displayed.			

5.3 Audible alarm

During a utility failure or fault operation, the Inverter emits beep for warning. In back-up mode, the alarm can be silenced by pushing the button. However, the warning of low battery will still sound for urging user to leave computer without any data loss.

Basic Indication Table:

	STATUS	ALARM	REMARK (LED)
Idle mode	Utility Good	No Beep	Green (flash)
	Utility outage	No Beep	Orange (flash)
	Timer on, (refer to Item 5.5)	No Beep	Red (flash)
Normal / Back-up mode	Normal (Utility good)	No Beep	Green
	Back-up (No load)	One beep every 4 sec. (alarm can be silenced).	Orange (flash)
	Back-up (Loaded)	2 beeps every 8 sec. (during 1 st minute of blackout).	
	Battery Low	4 beeps per sec. (alarm can Not be silenced).	Orange (flash)
Abnormal Condition	Over load	Continuous alarm (alarm can Not be silenced).	Red
	Inverter fault	Every other 2 sec., 32 beeps in 2 sec (alarm can Not be silenced).	Red (flash)
	Thermal alarm	Every other 2 sec., 32 beeps in 2 sec (alarm can Not be silenced).	Red (flash)

5.4 Auto Self-test Function

In normal mode of Inverter, turn on your computer and push the button on the front panel for self-test. The Inverter will simulate a power outage and transfer to battery mode. If low battery warning sounds during the test, it means that the battery set is weak and requires extended recharge.

5.5 Remote Control

The Inverter can be set for daily shutdown/wake up. This command must be set through the RS-232 interface. When this function is set, the timer inside the Inverter will begin to run, and the load will be turned off by the shutdown / wake-up schedule. During the period of turn-off to the next turn-on, the status LED blinks red every 2 seconds. For LCD version, the time period to next turn-on will be shown on LCD panel by hour (Ref. item 15 of LCD description).

5.6 Reset the Inverter

If any abnormal condition occurs, and the item 4.1 ~ 4.7 can not be executed, please unplug the line cord and push the button for at least 15 sec., which will reset the Inverter.

5.7 DIP Switch Settings



DIP 1	DIP 2	Charging current	NOTE of Charging current control :
Up	Up	25%	The setting of DIP 1 & 2 is valid only when the DIP3 = Down, which also means that the charger (built in the main PCB) is ON so that the charging current is adjustable, 25%~100%. While if the DIP3 = Up, it means that the built-in charger is OFF.
Down	Up	50%	
Up	Down	75%	
Down	Down	100%	
DIP 3 = Down, Charger turned ON ; DIP 3 = Up, Charger turned OFF.			
DIP 4 for Green Mode setting UP = Enable / Down = Disable			

P.S.: The setting active only after the inverter is re-started.

6. COMMUNICATION INTERFACE

The Inverter provides two computer interfaces, smart software (RS-232 and USB, optional). The RS-232 also includes dry contact (DB-9, optional) for different monitoring application. The models with USB interface are applying the same control port for both USB & RS-232 so that the only interface can be used at the same time.

6.1 The definition and setup for RS-232 is shown as follows:

Baud Rate : 2400 dps

Data Length : 8 bits

Stop Bit : 1 bit

Parity : None

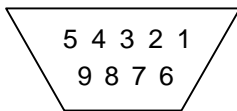

Pin #6 : RS-232 data Tx out.

Pin #7 : Common of Pin #6 and Pin #9

Pin #9 : RS-232 data Rx In

6.2 The definition and setup for DB9 (optional) is shown as follows:

Pin #2 : AC Power Failure

Pin #4 : Common GND of Pin #2 & Pin #5

Pin #5 : Inverter Battery Low

Pin #6 : Turn off Inverter

Pin #7 : GND of Pin6

The interface with computer is diagramed as above for your reference. Use Pin #4 as the common of Pin #2 and Pin #5, Pin #2 and Pin #4 will become close loop from open when the utility fails, Pin #5 and Pin #4 will become close loop from open when the battery level is low.

The Inverter will shut down itself when the high level from RS-232, sustained for 3 seconds, which is applied between Pin #6 and Pin #7.

7. TROUBLE SHOOTING

Problem	Possible Cause	Action to Take
Inverter no reaction while AC is connected	<ol style="list-style-type: none"> 1. Line cord plug is loose 2. Fuse on rear panel blown (Inside the drawer of inlet) 3. Dead wall socket 	<ol style="list-style-type: none"> 1. Check the line cord plug 2. Replace fuse 3. Check wall socket with a table lamp.
Power output is normal, Inverter emits continuous beep, status LED shows RED, or LCD shows "overload".	Inverter is over loaded	Turn off Inverter and unplug excessive loads from the Inverter.
No power on outlets, Inverter emits continuous beep, status LED show RED or LCD shows "over load".	Inverter has shut down due to severe overload.	Unplug excessive loads from Inverter, press button to reset the buzzer, and turn on the Inverter again.
Inverter does not provide expected run time	<ol style="list-style-type: none"> 1. Excessive loads connected at Inverter's outlets. 2. Battery is weak and cannot provide enough capacity. 	Do not operate the Inverter, & leave the Inverter plugged in for 10 hours. Then, test it again, if Inverter still can not provide expected run time, the battery should be replaced.
Button on front panel doesn't work	<ol style="list-style-type: none"> 1. The CPU inside Inverter is not running correctly. 2. Button damaged. 	<ol style="list-style-type: none"> 1. Unplug the line cord & push the button for 15 seconds to reset the Inverter. 2. Unplug all loads and line cord from the Inverter to let it off automatically, and call for service.
To push button for testing under AC mode, Inverter emits urgent beep and LCD display shows "battery replacement" at the same time.	Battery is weak and should be replaced	Replace batteries.
Inverter cannot be turned on.	<ol style="list-style-type: none"> 1. Battery polarity wrong 2. Inverter fault 	<ol style="list-style-type: none"> 1. Check battery connection. 2. Call for service.

8. SPECIFICATIONS

Home Inverter 800 / 1.2K / 1.6K / 2.4K / 3.2K / 4KVA

General Features:

- ◆ Adjustable voltage-transfer points & charging voltage
- ◆ Generator compatible & Cold-start capable
- ◆ Automatic restart of load after inverter shutdown
- ◆ Smart AVR function (Two buck / boost modes)
- ◆ Wide input range 140V~310V for 230V area; and 70V~155V for 115V area.
- ◆ Audible alarm
- ◆ Full function of LED display (LCD display optional)
- ◆ Smart battery management with big charger, Wet battery compatible
- ◆ Intelligent double stages of charging control; Adjustable charging current by DIP for different battery
- ◆ Thermal control cooling fan
- ◆ With DC/AC Isolation
- ◆ Support Solar panel input for charger (Optional)

Output

	115V Models	230V Models
Power Levels crated at nominal inputs	800VA / 600W ; 1200VA / 900W 1600VA / 1200W ; 2400VA / 1800W 3200VA / 2400W ; 4000VA / 3000W (4K for 230V only)	
Output Voltage	100V/110V/115V/120V Selectable	200V/220V/230V/240V Selectable
Voltage Waveform	Pure Sine wave	
Crest Factor	3 : 1	
Output Frequency (Synchronized to Mains)	Auto Select for 50/60Hz 47Hz ~ 55Hz for 50Hz nominal 56Hz ~ 65Hz for 60Hz nominal	
Regulation (Nominal)	±10% typical of nominal voltage	
Regulation (Battery mode)	±3% of selected output voltage (adjustable with the remote set-up software)	
Transfer time	Blackout 3ms typical Brownout 1ms typical Battery mode to Normal mode : 1ms typical	
Over current protection	Over load alarm level 100% ~ 120% Over load shutdown level 120% ~ 190% (Adjustable by using the remote set-up software)	

Input

	115V Models	230V Models
Nominal Voltage	100V/110V/115V/120V Selectable	200V/220V/230V/240V Selectable
Input Frequency	47Hz ~ 65Hz, 50/60Hz auto-sensing	
Efficiency (Normal mode)	97%	
Noise Filtering	Full time EMI/RFI filtering	
Over current protection	Re-settable over current protector : 800VA ~ 3200VA	AC Fuse : 800VA / 1200VA Re-settable over current protector : 1600VA ~ 4000VA
Voltage Range	70V ~ 155V	140V ~ 310V

AVR Range (2 Bucks, 2 Boosts)	Enhanced Buck: +28% of selected nominal voltage Buck mode: +10% of selected nominal voltage Boost mode: -10% of selected nominal voltage Enhanced Boost: -25% of selected nominal voltage	
Surge Protection	800VA / 1200VA : 216 Joules 1600VA ~ 3200VA : 324 Joules	800VA / 1200VA : 220 Joules 1600VA ~ 4000VA : 440 Joules

Battery

Battery type	Lead-Acid 50Ah ~ 500Ah (Recommended)	
Voltage	800VA / 1200VA : 12Vdc ; 1600VA / 2400VA : 24Vdc 3200VA : 36Vdc ; 4000VA : 48Vdc	
Typical backup time	No Limit	
Charging method	Smart pulse charging with two charging modes : Quick charging when battery is not fully charged, trickle charging when battery is 90% fully charged.	
Maximum charging current	800VA : 20A / 1200VA : 30A / 1600VA : 25A 2400VA : 35A / 3200VA : 30A / 4000VA : 30A	
Average charging voltage for each battery	Quick charging mode : 14V maximum. Trickle charging mode : 13.5V (adjustable with the remote set-up software)	
Protection	Over current protection & Over charging voltage protection (SCR control) Thermal protection (CPU control) When temperature inside the unit is over 45°C, charger will stop charging for 2 minutes followed by an 2 minutes charging. The cycle will be repeated until the temperature is lower than 44°C.	
Monitoring	Smart monitoring & warning for failed battery or open-circuit battery. Auto-detection each time when power on or every 6 days.	

Solar Charger (optional)

Rating voltage	12V / 24V / 36V / 48V	
DC input range	12V model : 12 ~ 21Vdc 24V model : 24 ~ 42Vdc 36V model : 36 ~ 63Vdc 48V model : 48 ~ 84Vdc	
Charging method	Constant voltage with current limiting by PWM control	
Charging voltage	12V model : 13.5Vdc 24V model : 27.0Vdc 36V model : 40.5Vdc 48V model : 54.0Vdc	
Power rating	12V model : 500W (13.5Vdc @ 37A) 24V model : 1000W (27.0Vdc @ 37A) 36V model : 1000W (40.5Vdc @ 25A) 48V model : 1000W (54Vdc @ 18.5A)	
Protection	DC input polarity protection, DC input short circuit protection(when battery is connected), DC output over current protection	

Communications & Management

Standard Interface port	UPSilon2000 compatible; optional for RS232 and/or USB.	
Optional Interface part	RJ45 (Surge protection), DB9, SNMP (external type)	
Control panel	LCD or LED Selectable	
Audible alarm	Alarm on battery : Low battery & Battery over voltage Alarm on abnormal operation : Over load, Short-circuit, & Over heat	
Green mode function (Auto-shut-off in blackout)	1% to 14% of full load (adjustable by using the remote set-up software) The default setting is OFF.	
Cooling fan control	Auto on / off, controlled by temperature & operation mode	

Environmental and Safety

Operating Temperature	Up to 1500 meters : 0°C to 40°C (32°F to 104°F)
Transit/storage Temp.	-15°C to 55°C (5°F to 131°F)
Relative Humidity	5 - 95% non condensing
Operating Altitude	0 ~ 3000 meters
Quality control system	ISO 9001

Physical

Dimensions: (DxHxW) Unit / Shipping	800VA / 1200VA (Wall-mount) : 12 x 25 x 37 (cm) / 22 x 31 x 47 (cm) 800VA / 1200VA (Tower type) : 38 x 20 x 18 (cm) / 48 x 33 x 30 (cm) 1600VA / 2400VA : 45 x 20 x 18 (cm) / 54 x 33 x 30 (cm) 3200VA / 4000VA : 51 x 20 x 18 (cm) / 61 x 33 x 30 (cm)
Weight: Net / Gross (kg)	800VA : 10/11 (kg) (Wall-mount) / 1200VA : 13/14 (kg) (Wall-mount) 800VA : 12 /13 (kg) / 1200VA : 15/16 (kg) 1600VA : 19 / 21 (kg) / 2400VA : 25 / 27 (kg) 3200VA : 33 / 35 (kg) / 4000VA : 40 / 42 (kg)
Packing	Export carton for each unit, 16 - 30 units per pallet