

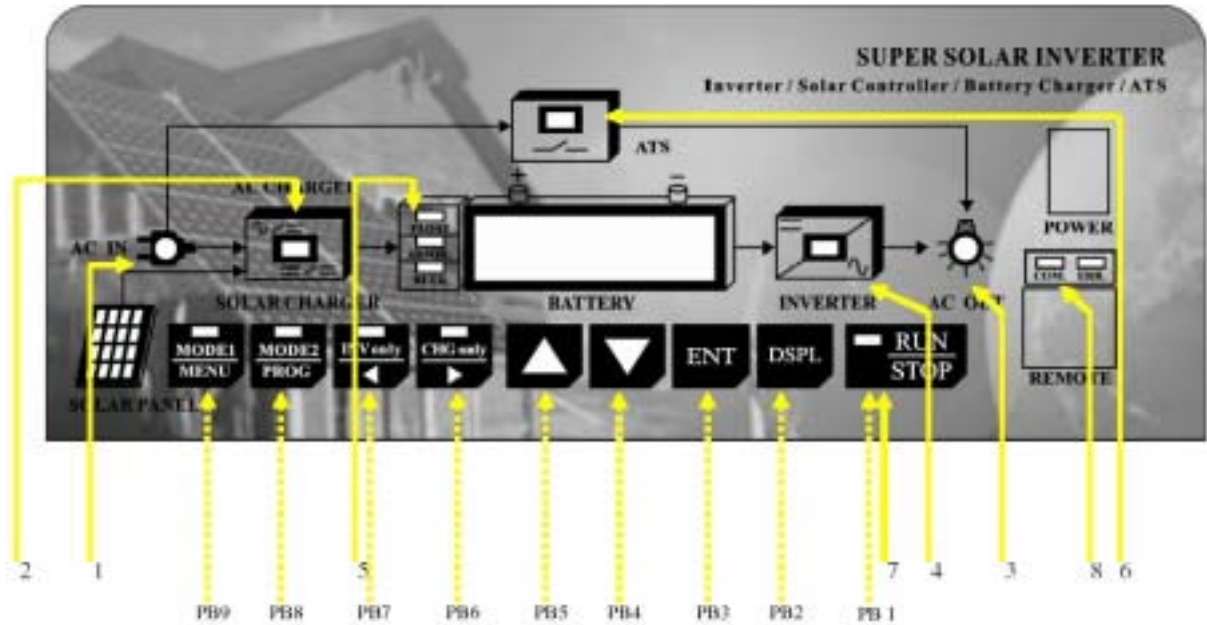



# Chapter 3 Wiring

## 3.1 Front Panel Display







### Push Buttons

Push buttons	Name	Description
PB1	RUN/STOP	SSL series RUN/STOP key
PB2	DSPL	Multi-display select key
PB3	ENTER	Data write-in key
PB4	DOWN ( )	Decrement key
PB5	UP ( )	Increment key
PB6		AC Input power to charge the battery. Function Key to move Cursor to the right digit at Parameter Edit.
PB7		DC power from battery to supply to AC loads. Function Key to move Cursor to the left digit at Parameter Edit.
PB8		AC Generator Support with Dynamic Power Shifting. Function Key to return to Main Menu “Programming”
PB9		AC Power as Priority Support. Function Key to return to Main Menu “Operation”.

Before changing from one mode to another, it has to stop running and be in STOP mode.

Note:

1. When pressing RUN/STOP key, the holding time to remain on the key has to be at least 2 seconds (initial setting) to activate the RUN or STOP function in order to avoid any accidental pressing on the RUN/STOP key. The second time can be adjusted in RUN/STOP KeyHoldTime (O2-07).
2. When changing any of four modes to another mode, SSL series has to STOP and then press the desired mode key. When pressing MODE 1 key or MODE 2 key or INV only key or CHG only key, the holding time remaining on the key has to be at least 5 seconds (initial setting) to activate the mode change in order to avoid any accidental pressing on the mode keys. The second time can be adjusted in MODE Key Hold Time (O2-06).
3. The beep sound of key pressing can be selected to be enabled or disabled in Key Pressed Beep Sel (O2-01)
4. When all the keys are not pressed at all for a certain time (O1-02), it goes to idle mode. Once any key is pressed, the display will return to the LCD monitor selection value set in constant O1-01.
5. When all the keys are not pressed at all for a certain time (O2-09), all the LCD Display and LED Indicators are not active but RUN/STOP indicator remains active. The display idle function can save the display power.
6. When users are programming under any level of Groups or Function or Parameters or Parameters Edit, press  key for 1 second to return to Main Menu "Operation" immediately.
7. When users are programming under any level of Groups or Function or Parameters or Parameters Edit, press  key for 1 second to return to Main Menu "Programming" immediately.
8. When adjusting the parameters values, press  key to key to enable cursor to move left for one digit and press  key to enable cursor to move right for one digit.

## LED Indicators

LED	Name	L ED ON	LED OFF
1	AC IN	1. Input voltage normal, and position > "transfer Voltage Level" (150VAC~240VAC) 2. Input voltage frequency range in between(45~65Hz)	No input power
2	AC CHARGER	Green : Battery charger is working.	-----
3	AC OUT	There is voltage at the "AC OUT" terminal.	-----
4	INVERTER	Green : Inverter is working.	-----
5	BATTERY	FLOAT or ABSOR. Or BULK charge state of battery.	-----
6	ATS	Green : ATS switch is active AC IN voltage is being sent directly to AC OUT terminal	-----
7	RUN/STOP	Green : SSL series turn on. Red : SSL series turn off.	-----
		NOTE: Green Blink : Auto-Restart is in use	
8	COM./ERR.	Remote control port in communication/in error	

## 3.2 Panel Connection

### 3.2.1 Lower-Front Panel Connection for Wall-Mounting/Vertical SSL series

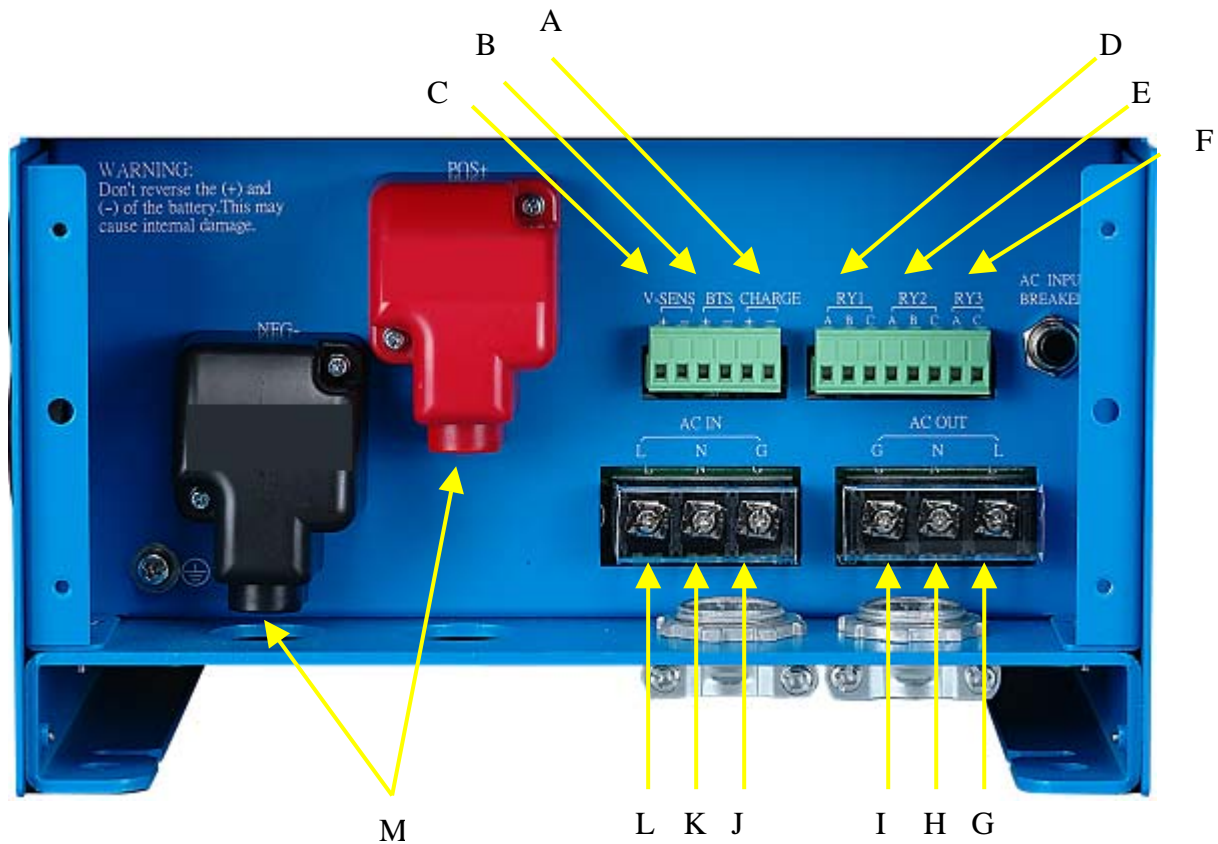

#### Connections / Lower-Front side for wall mounting

A CHARGE	Connecting terminal for starting battery of 4A
B BTS (Battery temp. sensor)	Connecting terminal for temperature sensor
C Vsens +/- (Battery Voltage Sense)	Connecting terminal for Battery Voltage feedback
D RY1 contact	Connecting terminal for auxiliary contact 1
E RY2 contact	Connecting terminal for auxiliary contact 2
F RY3 contact	Connecting terminal for auxiliary contact 3
G AC OUT L	Connecting terminal for AC output Line
H AC OUT N	Connecting terminal for AC output Neutral
I AC OUT G	Connecting terminal for AC output Ground
J AC IN G	Connecting terminal for AC input Ground
K AC IN N	Connecting terminal for AC input Neutral
L AC IN L	Connecting terminal for AC input Line
M Battery POS+ / NEG-	Battery cables

### 3.2.2 Rear Panel Connection for Table-Mounting/Horizontal SSL series

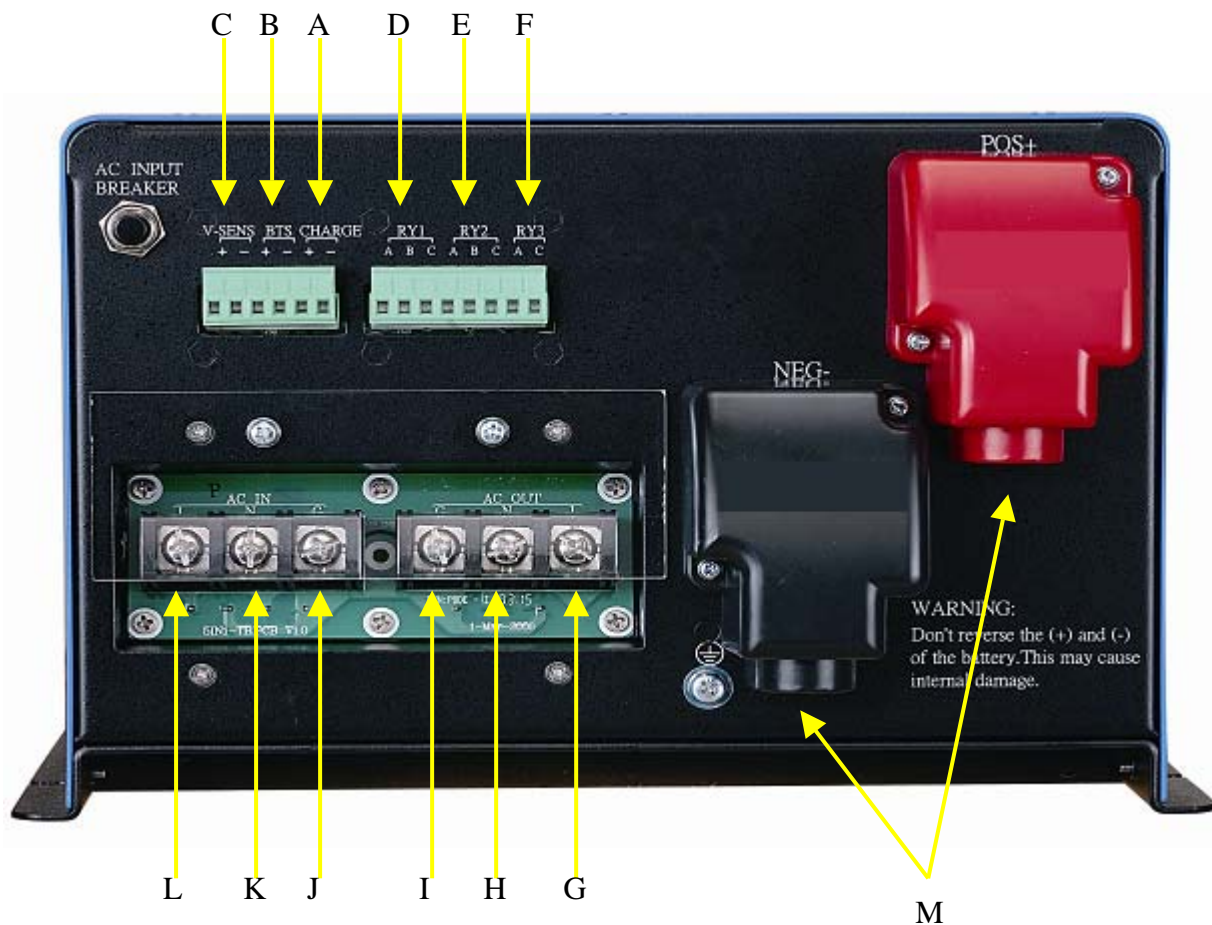

#### Connections / Rear side for table mounting

A CHARGE	Connecting terminal for starting battery of 4A
B BTS (Battery temp. sensor)	Connecting terminal for temperature sensor
C Vsens +/- (Battery Voltage Sense)	Connecting terminal for Battery Voltage feedback
D RY1 contact	Connecting terminal for auxiliary contact 1
E RY2 contact	Connecting terminal for auxiliary contact 2
F RY3 contact	Connecting terminal for auxiliary contact 3
G AC OUT L	Connecting terminal for AC output Line
H AC OUT N	Connecting terminal for AC output Neutral
I AC OUT G	Connecting terminal for AC output Ground
J AC IN G	Connecting terminal for AC input Ground
K AC IN N	Connecting terminal for AC input Neutral
L AC IN L	Connecting terminal for AC input Line
M Battery POS+ / NEG-	Battery cables

### 3.3 Battery Connection

#### 3.3.1 Star Connection Schematic

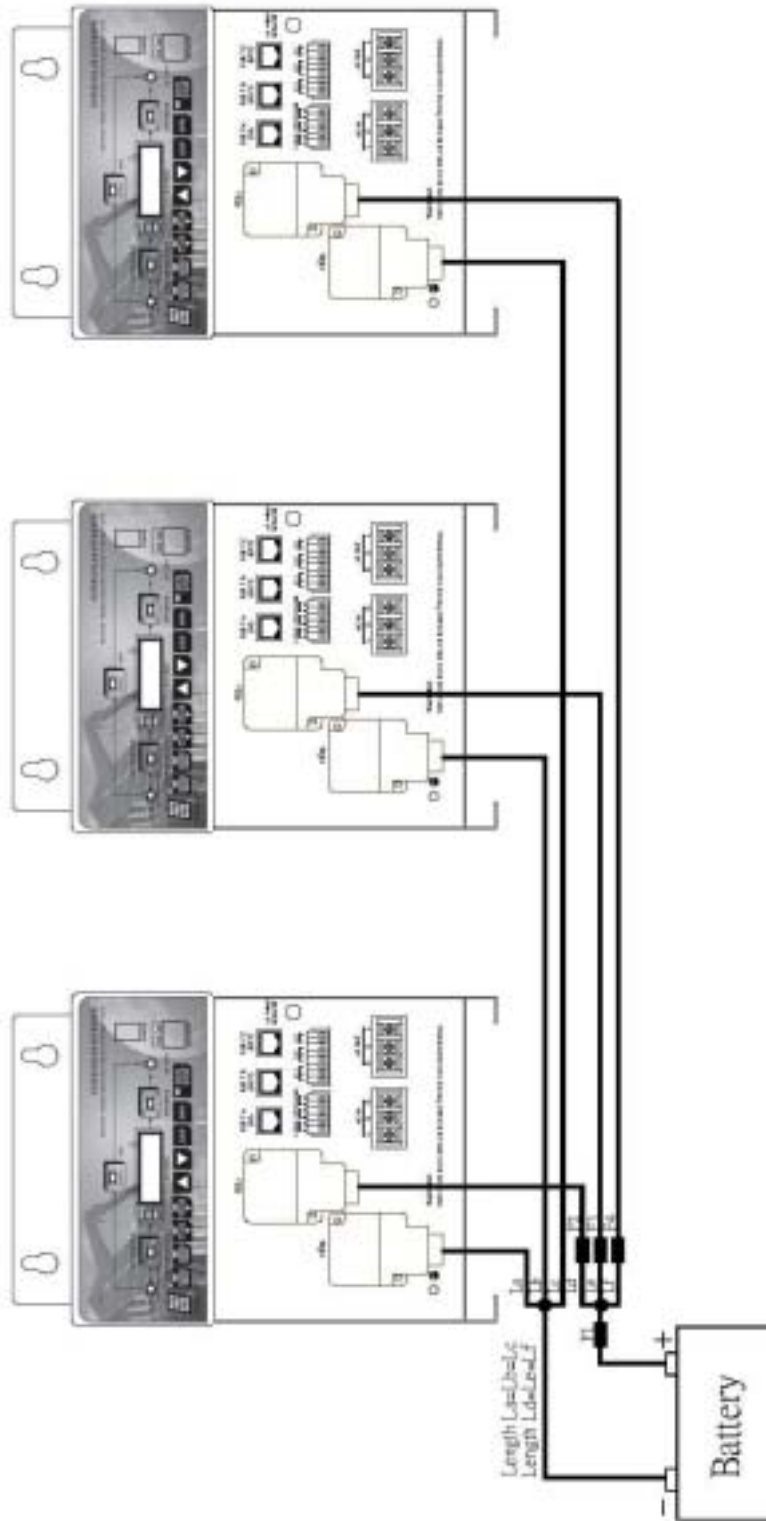

### 3.3.2 Rail Connection Schematic

